

SKETCH SHOWING GROSS LETTABLE AREA RETAIL (GLAR)  
 LEVEL 1 BIGPLACE AT LARGE SHOPPING CENTRE, BIGSVILLE  
 CLIENT: SAMPLE PTY LTD

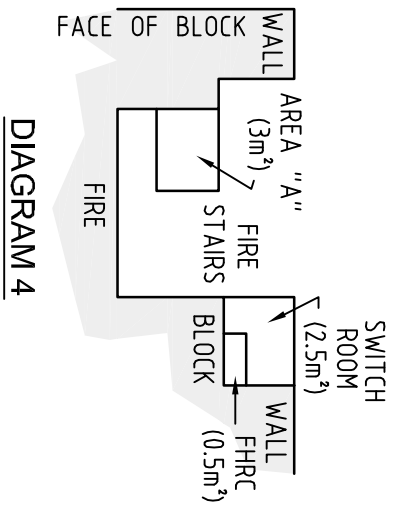

DIAGRAM 4

AREA "A" DENOTES AREA UNDER STAIRS WHERE HEIGHT ABOVE FLOOR LEVEL IS LESS THAN 1.5m AREA NOT INCLUDED IN STATED GLA(R)

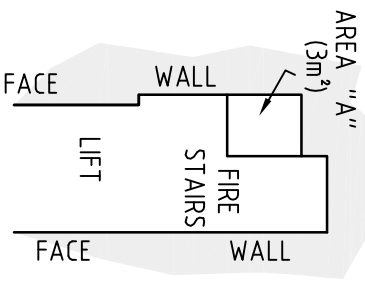
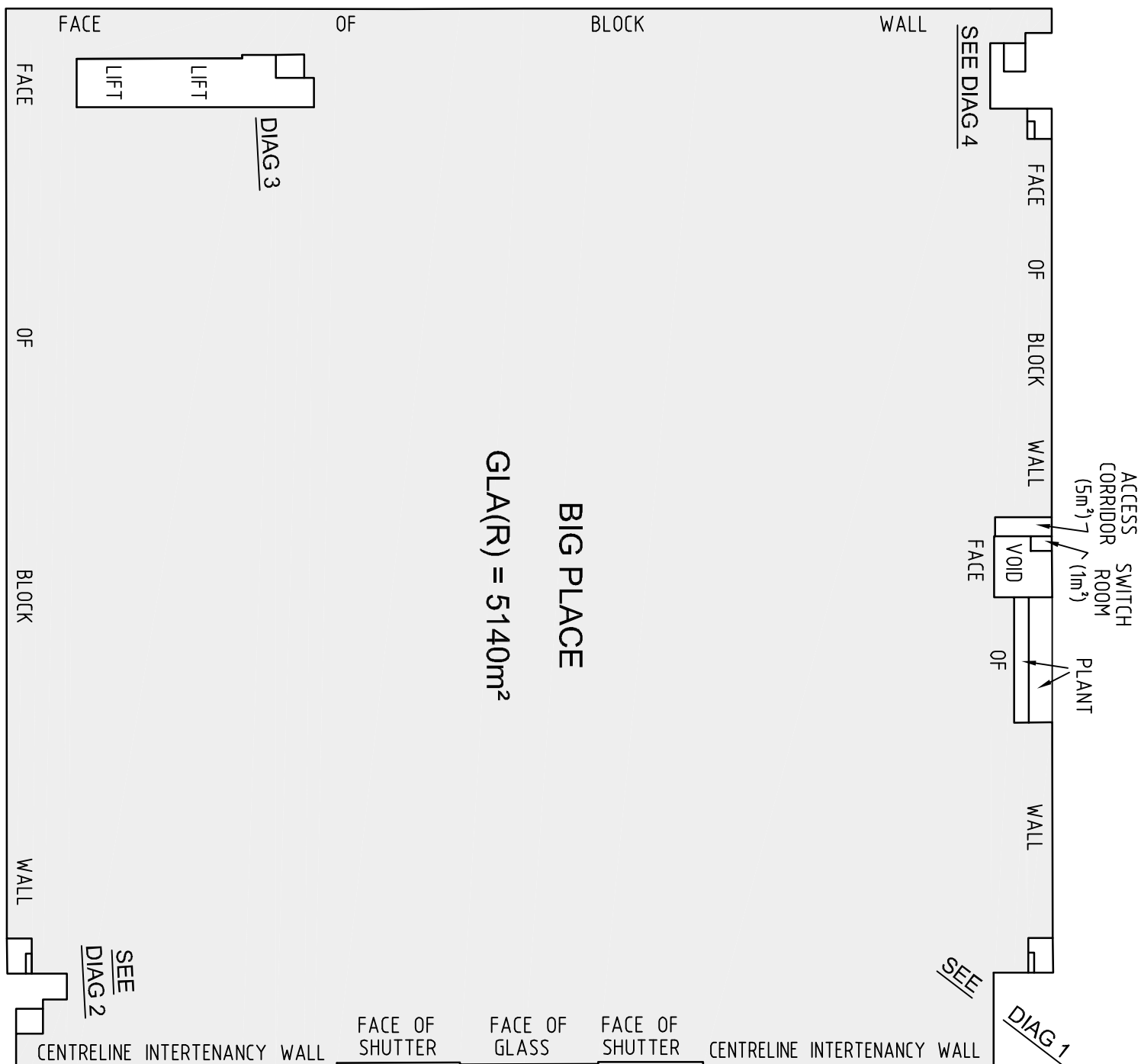

DIAGRAM 3



BIG PLACE

GLA(R) = 5140m²

MALL

TENANCY CURRENTLY OCCUPIED BY "BRAS N THINGS"

TENANCY CURRENTLY OCCUPIED BY "LEAGUE & LEGENDS"

FHRC – FIRE HOSE REEL CUPBOARD AREA NOT INCLUDED IN STATED GLA(R)

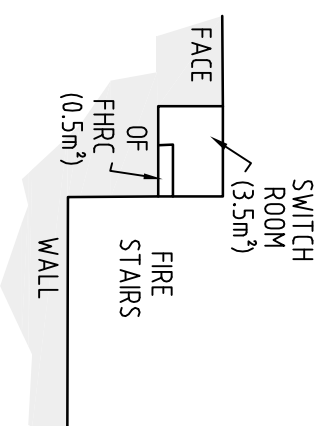

DIAGRAM 1

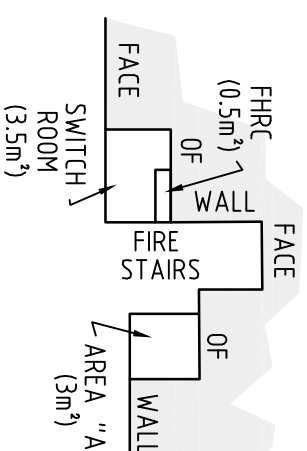



DIAGRAM 2

SHEET 3 OF 4 SHEETS

- AREA OF COLUMNS HAVE BEEN INCLUDED AREA OF DUCTS HAVE BEEN EXCLUDED
- THIS SKETCH MUST BE READ IN CONJUNCTION WITH MY REPORT REF: PCASAMPLE4
- TOTAL GLAR ROUNDED TO NEAREST 5m² IN ACCORDANCE WITH INSTITUTION OF SURVEYORS NSW GUIDELINES SP03/17
- AREAS MEASURED AND CALCULATED GENERALLY IN ACCORDANCE WITH THE PROPERTY COUNCIL OF AUSTRALIA METHOD OF MEASUREMENT FOR LETTABLE AREA GUIDELINES MARCH 1997 EDITION
- MEASUREMENTS TAKEN TO STATED SURFACES

DATE OF SURVEY: SAMPLE 2009  
 REF No. PCASAMPLE4

© PROJECT SURVEYORS-2009  
 REPRODUCTION WITHOUT WRITTEN APPROVAL IS STRICTLY PROHIBITED



Liability Limited by a Scheme Approved under Professional Standards Legislation

**MACQUARIE PARK**  
 PO Box 4004  
 MACQUARIE CENTRE NSW 2113  
 SUITE 404, LEVEL 4  
 No13-15 LYON PARK ROAD,  
 MACQUARIE PARK NSW 2113  
 PHONE : 9888 3848  
 FAX : 9888 3875  
 email: office@projectsurveyors.com.au  
 www.projectsurveyors.com.au  
 ABN 20 068 433 974



**PROJECT SURVEYORS**  
 Professional Innovative... Results.